

# HAUL-MASTER®



## FLATBED TRAILER WITH ATV TIRES

Model 47845

### ASSEMBLY and OPERATING INSTRUCTIONS

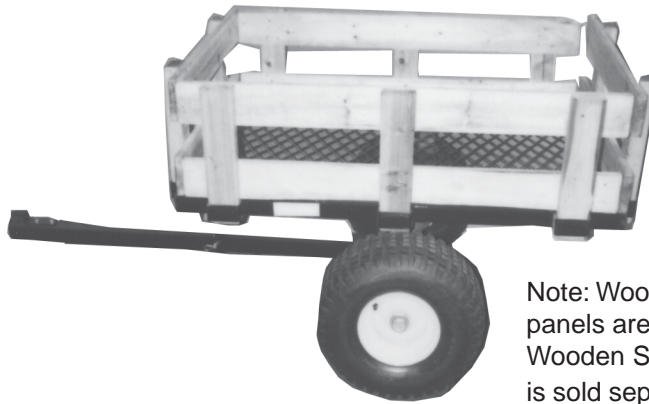

Note: Wooden stake panels are not included. Wooden Stake Kit, #40041 is sold separately.

**Flatbed Trailer is for off-road use only.**

Due to continuing improvements, actual product may differ slightly from the product described herein.



3491 Mission Oaks Blvd., Camarillo, CA 93011  
Visit our Web site at <http://www.harborfreight.com>

Copyright© 2002 by Harbor Freight Tools®. All rights reserved. No portion of this manual or any artwork contained herein may be reproduced in any shape or form without the express written consent of Harbor Freight Tools.

For technical questions and replacement parts, please call 1-800-444-3353

REV 08/05

## Specifications

Maximum Load Capacity	1000 Lbs.
Bed Dimensions	51-1/2" L x 37-3/8" W (8 gauge)
Cross Member Dimensions	29-7/8" L x 6-5/8" W x 1-3/4" H (13 gauge)
Tow Bar Dimensions	50-3/4" L x 3-1/4" W x 2" H (12 gauge)
Axle Size	39" L (with spindle) x 1-1/2" W x 1-1/8" H (9 gauge)
Tires	12 PSI, 18 x 9.5-8 Tubeless Nylon ( <b>Not for highway use</b> )
Hitch	6" L x 1-1/2" W x 1-3/8" H (6 gauge)

## Save This Manual

You will need the manual for the safety warnings and precautions, assembly instructions, operating and maintenance procedures, parts list and diagram. Keep your invoice with this manual. Write the invoice number on the inside of the front cover. Keep the manual and invoice in a safe and dry place for future reference.

## Safety Warnings and Precautions

**WARNING: When using or assembling tool, basic safety precautions should always be followed to reduce the risk of personal injury and damage to equipment.**

**Read all instructions before using this tool!**

1. **Keep work area clean.** Cluttered areas invite injuries.
2. **Observe work area conditions.** Keep work area well lighted.
3. **Keep children away.** Children must never be allowed in the work area. Do not let them handle the Trailer or tools during assembly.
4. **Store idle equipment.** When not in use, the Trailer must be stored in a dry location to inhibit rust. Always lock up tools and keep out of reach of children.
5. **Use the right Trailer for the job.** Do not attempt to force a small Trailer to do the work of a larger industrial Trailer. There are certain applications for which this Trailer was designed. It will do the job better and more safely at the rate for which it was intended. Do not modify this Trailer and do not use this Trailer for a purpose for which it was not intended.
6. **Dress properly.** Do not wear loose clothing or jewelry as they can be caught in moving parts. Protective, electrically nonconductive clothes and nonskid footwear are recommended when working. Wear restrictive hair covering to contain long hair.
7. **Use eye protection.** Always wear ANSI approved impact safety goggles during assembly.
8. **Do not overreach.** Keep proper footing and balance at all times.

9. **Maintain Trailer with care.** Keep Trailer clean for better and safer performance. Follow instructions for lubricating and changing accessories. Inspect Trailer periodically, and if damaged, have it repaired by an authorized technician.
10. **Stay alert.** Watch what you are doing, use common sense. Do not operate Trailer when you are tired.
11. **Check for damaged parts.** Before using Trailer, any part that appears damaged should be carefully checked to determine that it will operate properly and perform its intended function. Check for alignment and binding of moving parts; any broken parts or mounting fixtures; and any other condition that may affect proper operation. Any part that is damaged should be properly repaired or replaced by a qualified technician.
12. **Replacement parts and accessories.** When servicing, use only identical replacement parts. Use of any other parts will void the warranty. Only use accessories intended for use with this Trailer. Approved accessories are available from Harbor Freight Tools.
13. **Do not operate Trailer if under the influence of alcohol or drugs.** Read warning labels on prescriptions to determine if your judgment or reflexes are impaired while taking drugs. If there is any doubt, do not operate the Trailer.
14. **Maintenance.** For your safety, maintenance should be performed regularly by a qualified technician.
15. **This Trailer is not designed for highway or night use. Flatbed Trailer is for off-road use only.**

**Warning: The warnings, cautions, and instructions discussed in this instruction manual cannot cover all possible conditions and situations that may occur. It must be understood by the operator that common sense and caution are factors which cannot be built into this product, but must be supplied by the operator.**

## **Unpacking**

When unpacking, check to make sure the parts listed on page 6 are included. If any parts are missing or broken, please call Harbor Freight Tools at the number on the cover of this manual as soon as possible.

## Assembly

Refer to the Assembly Drawing on page 7.

1. Attach the four **Support Panels (A2)** to the **Axle (A6)** using four **Bolts (B1)** and **Lock Nuts (B2)**. Set aside.
2. Attach the **Connect Bar (A5)** to the **Tow Bar (A4)** with two **Bolts (B5)** and two **Lock Nuts (B6)**.
3. Attach the **Support Bracket (A3)** to the **Tow Bar (A4)** with **L Pin (B7)** and secure it with cotter **R Pin (B8)**.
4. Connect the other end (the end without the **Connect Bar (A5)**) of the **Tow Bar (A4)** to the center of the **Axle (A6)** using **Bolt (B4)** and **Lock Nut (B2)**.
5. **WHEEL BEARINGS AND WHEEL ASSEMBLY**
  - A. The wheel bearings are shipped dry and **MUST** be packed with bearing grease prior to assembly. Wear latex gloves and apply grease liberally around the bearing rollers.
  - B. Wipe the two bearing races on each wheel clean. It is also recommended that the inside of the where the dust cap will go be wiped with some grease. This will remove surface rust and make the installation of the caps easier.
  - C. Insert the bearings into one wheel, matching the taper of the rollers to that of the races. Hold the bearings in place, while sliding the hub over the axle. Slide one large Washer (A8) over the spindle, then install and hand-tighten one Castle Nut (A9) to retain the wheel. Repeat with the other wheel.
  - D. Tighten the Castle Nut firmly, but not excessively. A 31mm socket wrench is best for this. Now back the nut off so that the nearest slot in the shoulder aligns with the cotter pin hole in the spindle. Test the wheel for free rotation. If necessary, loosen the nut another slot (1/6 of a turn), and check again. The wheel should rotate freely, yet have minimal side play on the spindle.
  - E. Insert the Cotter Pin (A10) through the slot and the spindle hole, then bend the longer leg up with small pliers. Repeat steps D and E on the opposite side.
  - F. The dust caps are intended to protect the bearing. They fit tightly and require some patience to install. Tap them in with a mallet.
6. Set the **Frame (A1)** so that the holes in the center of the bracket crossing the middle of the bed line up with the four holes on the top of the two **Support Panels (A2)**. Make sure the **Frame (A1)** is positioned with the two holes facing front (see Assembly Drawing on page 7). Loosely attach them with four **Bolts (B1)** and four **Lock Nuts (B2)**.
7. Attach the top of the **Support Bracket (A3)** to the two holes on the front of the **Frame (A1)** with two **Bolts (B3)** and **Lock Nuts (B2)**. Go back and tighten the hardware used in step 6 above.
8. If using wooden stake side panels (not included), slide the two side panels into the Bed Frame Sockets (see Assembly Drawing on page 7). Repeat with two front/rear panels. Make sure the vertical supports that fit into the sockets face the outside of the Trailer. Secure each side panel into the Bed Frame Sockets by inserting a screws (screws included in Wooden Stake Panel Kit).

REV 05/03; 12/03; 05/05

## Operation

**Note:** When loading or unloading the Trailer, always block both wheels on both sides of the wheels. See **FIGURE 1**.

**Note:** Always connect, load, and unload the Trailer on a flat, level, dry surface.

1. Attach the **Connect Bar (A5)** to the towing vehicle. Read the towing vehicle manual for towing and hitch connection procedures and safety warnings.
2. To tilt the Trailer as shown in **FIGURE 1**, hold onto the **Support Bracket (A3)** firmly while removing the **L Pin (B7)** and the cotter **R Pin (B8)**. Slowly tilt the bed. If using rear stake panel (not included), remove the panel and empty or load the Trailer. Replace the Rear Panel.
3. When finished, bring the bed back to the original position so that the hole on the **Support Bracket (A3)** lines up with the hole on the **Tow Bar (A4)**. Replace the **L Pin (B7)** and the cotter **R Pin (B8)**.

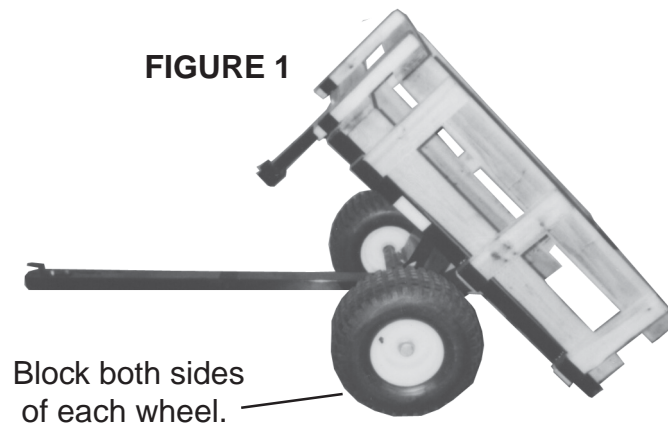

## Parts List

Part	Description	Qty.
A1	Frame	1
A2	Support Panel	4
A3	Support Bracket	1
A4	Tow Bar	1
A5	Connect Bar	1
A6	Axle	1
A7	Wheel (Bearing, Dust Cap)	2
A8	Large Washer	2
A9	Castle Nut	2
A10	Cotter Pin	2
B1	Bolt M10 X 16	12
B2	Lock Nut M10	15
B3	Bolt M10 x 65	2
B4	Bolt M10 x 100	1
B5	Bolt M8 x 16	2
B6	Lock Nut M8	2
B7	L Pin	1
B8	R Pin	1

## Maintenance

1. Periodically tighten all of the Trailer hardware.
2. Before each use, tap the Wheel Dust Caps with a rubber mallet and check the tires to make sure they are mounted securely.
3. Keep the **Connect Bar (A5)** clean of dirt, grease, or debris.
4. Make sure the tire pressure is at 12 PSI before each use.
5. When needed, lubricate inside the wheel hubs on the axle with high quality axle grease.

### PLEASE READ THE FOLLOWING CAREFULLY

THE MANUFACTURER AND/OR DISTRIBUTOR HAS PROVIDED THE PARTS DIAGRAM IN THIS MANUAL AS A REFERENCE TOOL ONLY. NEITHER THE MANUFACTURER NOR DISTRIBUTOR MAKES ANY REPRESENTATION OR WARRANTY OF ANY KIND TO THE BUYER THAT HE OR SHE IS QUALIFIED TO MAKE ANY REPAIRS TO THE PRODUCT OR THAT HE OR SHE IS QUALIFIED TO REPLACE ANY PARTS OF THE PRODUCT. IN FACT, THE MANUFACTURER AND/OR DISTRIBUTOR EXPRESSLY STATES THAT ALL REPAIRS AND PARTS REPLACEMENTS SHOULD BE UNDERTAKEN BY CERTIFIED AND LICENSED TECHNICIANS AND NOT BY THE BUYER. THE BUYER ASSUMES ALL RISK AND LIABILITY ARISING OUT OF HIS OR HER REPAIRS TO THE ORIGINAL PRODUCT OR REPLACEMENT PARTS THERETO, OR ARISING OUT OF HIS OR HER INSTALLATION OF REPLACEMENT PARTS THERETO.

**NOTE:** Some parts are listed and shown for illustration purposes only and are not available individually as replacement parts.

# Assembly Drawing

**Note:** Front, rear and side stake panels are not included.

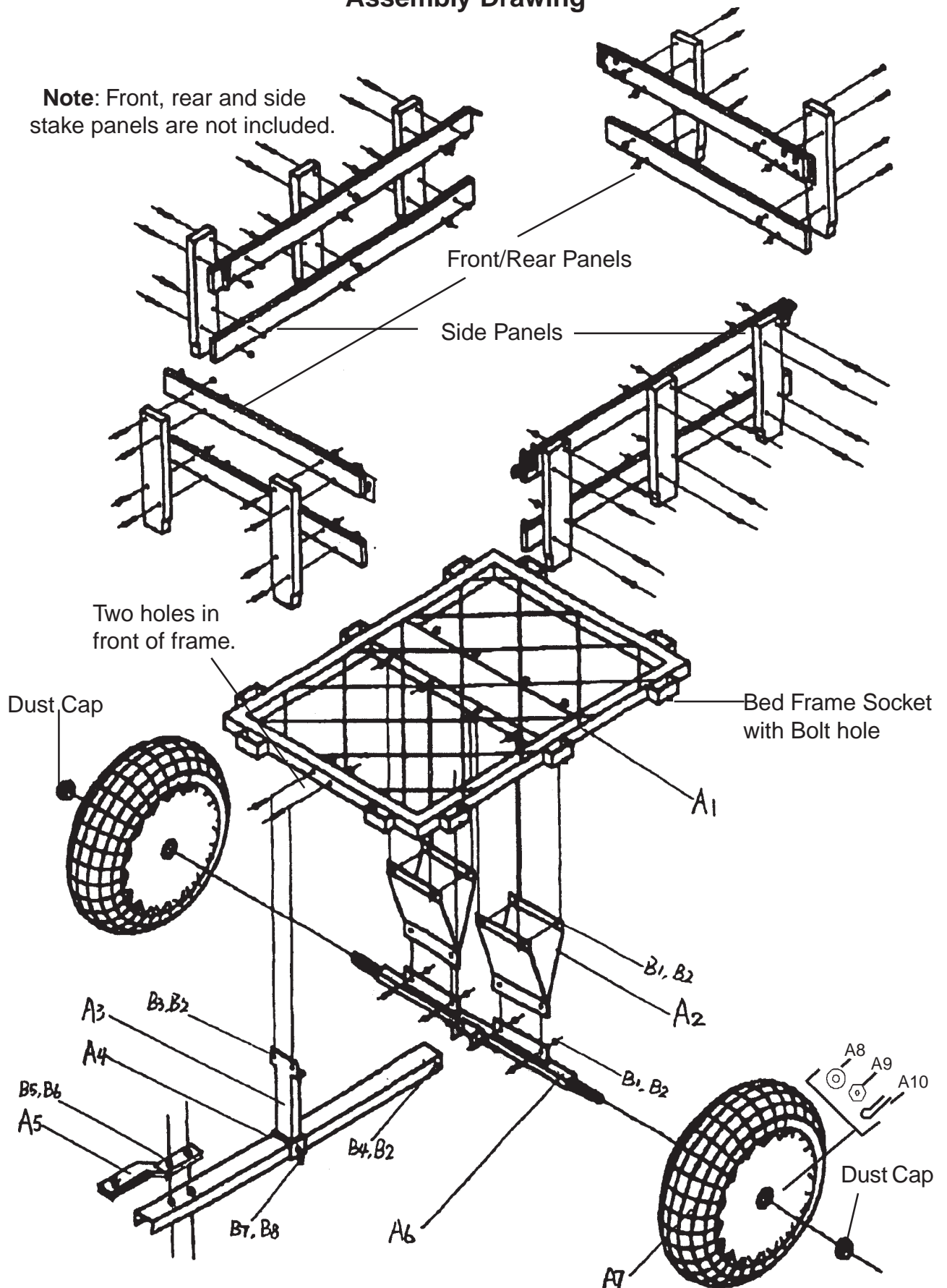

# Bearing Packing Instructions

---

## Important

Read and adhere to the following instructions; failure to read and obey all of the following instructions **COMPLETELY** will void the warranty and can result in damage to the trailer, property damage, or **SERIOUS PERSONAL INJURY**.

---

Whenever a hub is disassembled (if a hub on a new unit requires assembly or a hub is disassembled for maintenance), the following procedure **MUST** be followed.

1. Using a suitable solvent, thoroughly clean the bearings and the rest of the parts in the Hub assembly of all grease, dirt, metal shavings, or any other foreign object. **The parts must be cleaned even if they are new or *appear* clean.**
2. Allow all pieces to dry completely.
3. Make sure that your hands are thoroughly clean and the bearing packer (not included) is also thoroughly clean.
4. Place fresh, clean bearing grease in the packer.
5. With the grease-filled bearing packer in one hand and the bearing in the other, press the bearing into the grease, forcing the grease inside the slots in the bearing, continue doing this until every slot in the bearing is completely full of grease.
6. Finish assembling the hub/wheel assembly as explained in the manual, being careful not to get any dirt or debris on any part of the assembly.

**SAVE THESE INSTRUCTIONS.**